

# MAX2395 Output Matching to a SAW Filter for Optimum Cascaded Gain Flatness

*The output impedance of a TX SAW filter is a strong function of the source impedance seen at its input. The variation in the MAX2395's output port impedance reacting with the SAW filter and the following PA is enough to cause 3dB net gain variation over the band. A revised matching circuit between the MAX2395 and the TX SAW demonstrates improved gain flatness over the band – about 1dB total gain ripple.*

## Introduction

The MAX2395 is a single-band monolithic quasi-direct conversion modulator IC for WCDMA/UMTS applications. It is designed to yield near 50 $\Omega$  output impedance so that the only external matching components required between its RF output and the following SAW filter input are a pull-up inductor and a DC-blocking capacitor. Depending on how sensitive the SAW filter is to its source impedance, this simple match may be sufficient with the MAX2395 output's maximum return loss of 9dB.

However, in some instances, the SAW filter will generate ripples in its output impedance over frequency, depending on the presented source impedance. These impedance ripples will cause the cascaded gain to not be flat across the desired band. The severity of the amplitude ripple will depend on how susceptible the power amplifier (PA) following the SAW filter is to its source impedance (SAW output impedance). If the pass-band is too uneven, it is necessary to further tune the MAX2395 output match in order to obtain desired cascaded gain flatness. The Maxim WCDMA reference design presents a representative example of how to achieve optimum cascaded transmitter performance through adjusting the MAX2395 output matching when the SAW filter has a rippled S22.

## Gain Flatness over Frequency Band

The MAX2395 has a broad on-chip output match with better than 9dB return loss, as shown in Figure 1. Its gain flatness is better than 0.5dB over WCDMA band at room temperature when terminated with 50 $\Omega$ . However, when integrated with a popular SAW filter in the market and MAX2291 power amplifier in the Maxim WCDMA reference design, the whole transmitter has more than 3dB gain variation over the operational frequency band (1920-1980MHz), with minimum gain appearing at the middle of the band. Several tests were performed in investigation of the cause of the gain ripple. The block diagram in Figure 2 illustrates where the

evaluation measurements were taken in the TX system.

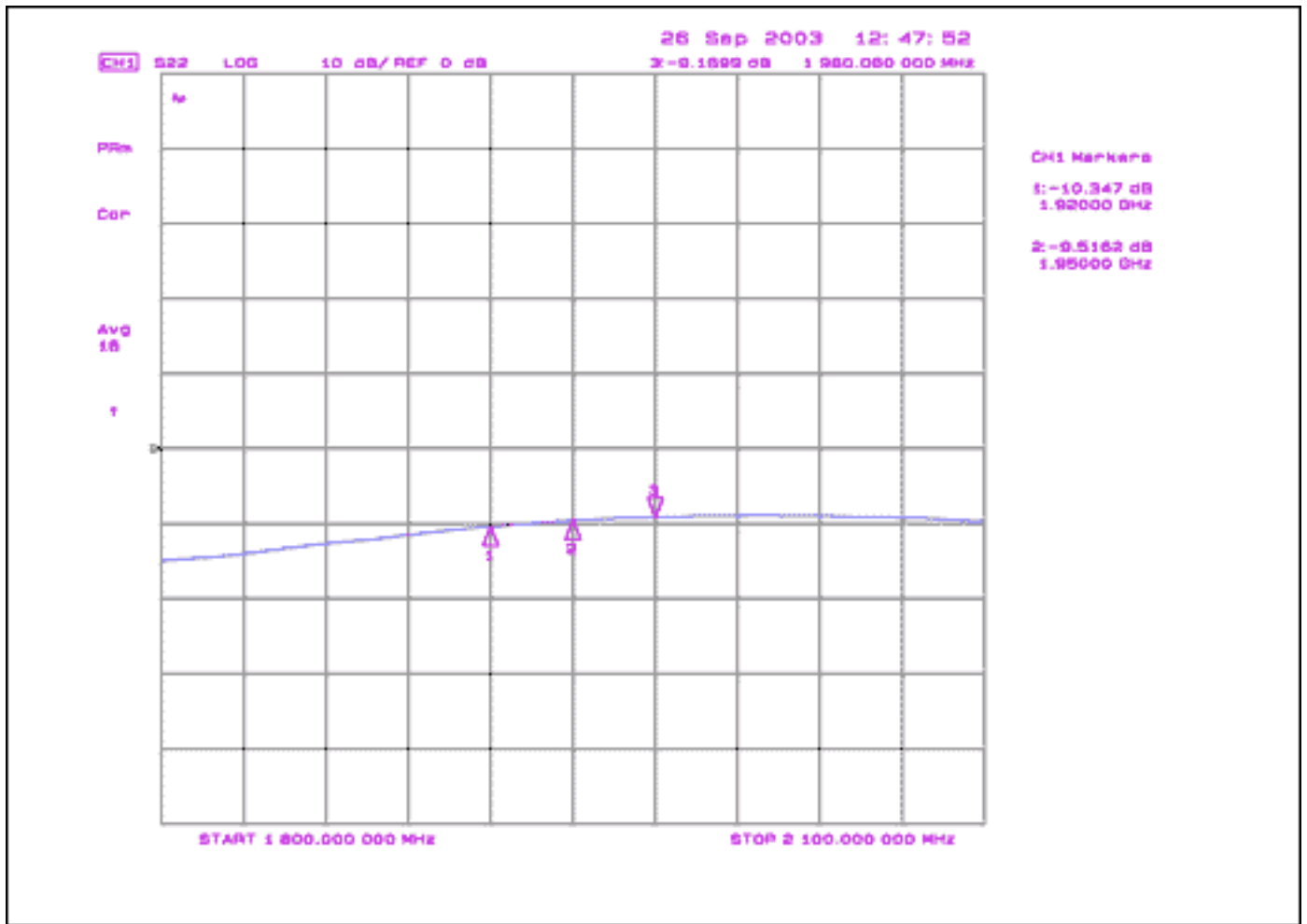

Figure 1. MAX2395 Output Return Loss.

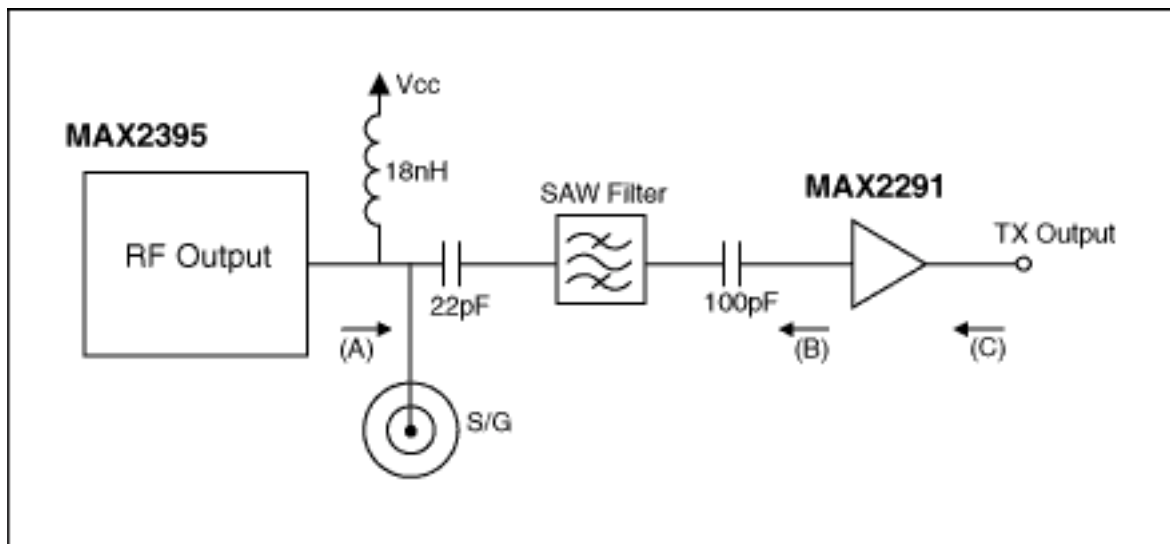

Figure 2. Three Test Points in a WCDMA TX Path.

### Test 1

When using MAX2395 RF output as a signal source at Point A and measuring output power at Point C, which is similar to practical applications, gain variation over frequency band is over 3dB

with lowest gain at middle band, 1950MHz.

## Test 2

When a signal generator is utilized as a signal input at Point A, the gain flatness measured at Point C is very good, less than 0.5dB. This means the SAW filter and PA have a flat gain over frequency band.

## Test 3

When using the MAX2395 as a input source and measuring at the SAW filter output, Point B, the gain flatness is also less than 0.5dB.

## Solution

Through the above tests, it can be concluded that all sections in the TX path provide good performance in terms of gain flatness over band. But the impedance interactions between sections are responsible for the large gain variation. The SAW filter's S22 then was measured when its input connected to the MAX2395 output. The S22 plot is presented in figure 3. The SAW filter S22 has a hump at middle band, which results in lower PA gain.

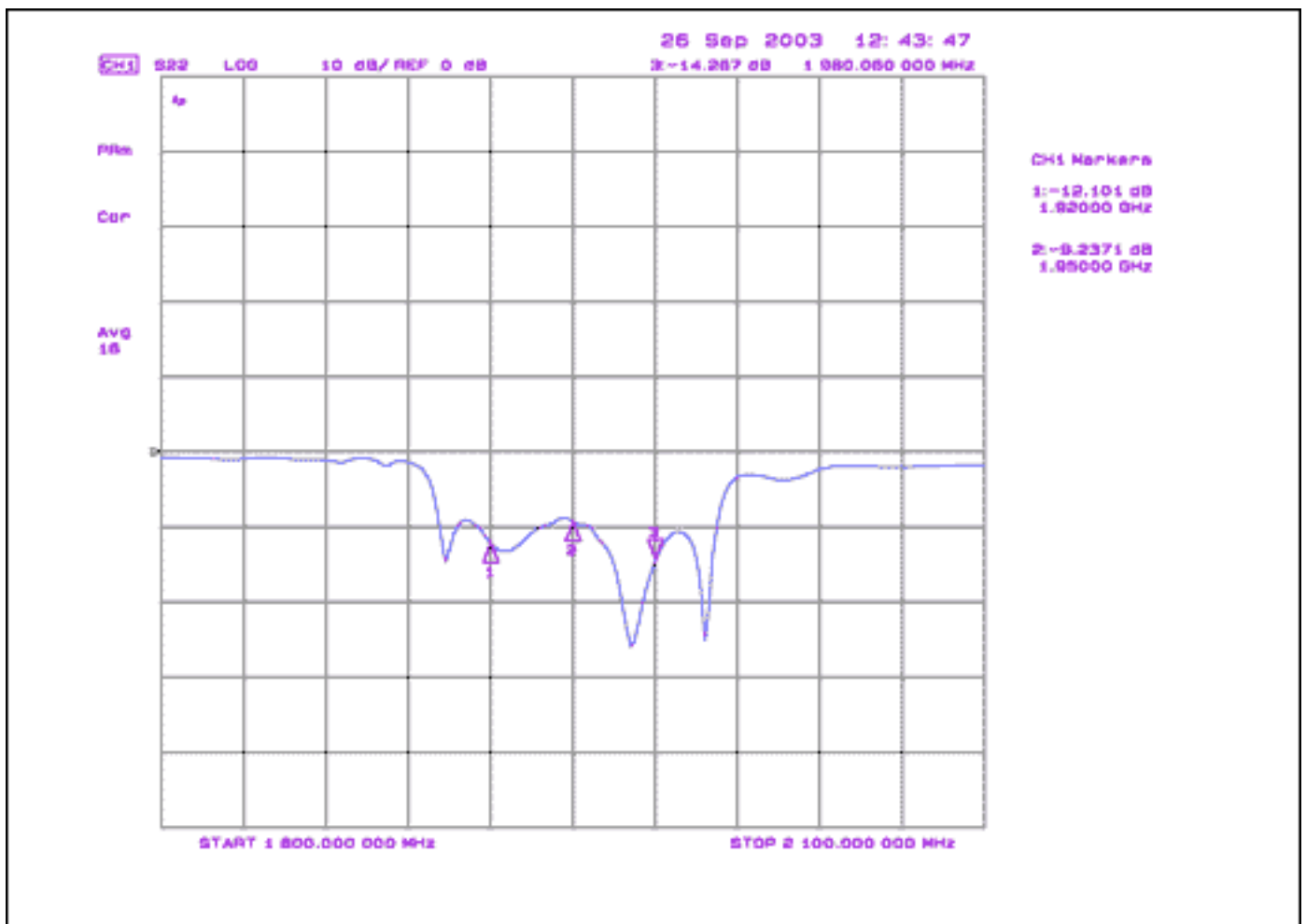

Figure 3. SAW filter output return loss, original matching circuit.

To improve cascaded TX gain flatness, a good approach is to adjust the MAX2395 output

matching while monitoring SAW filter output to achieve a better and flatter S22. After several trials and repeats, a desired matching in our case was obtained, which is shown in Figure 4. The resulting SAW filter S22 plot with the suggested MAX2395 output matching is given in Figure 5. The overall return loss now is much better than original with -12dB at the middle band. The measured output power variation at PA output, which is equivalent to cascaded TX gain variation, is shown in figure 6. It is around 1.0dB over WCMA frequency band. This will provide some simplicity to total TX power control.

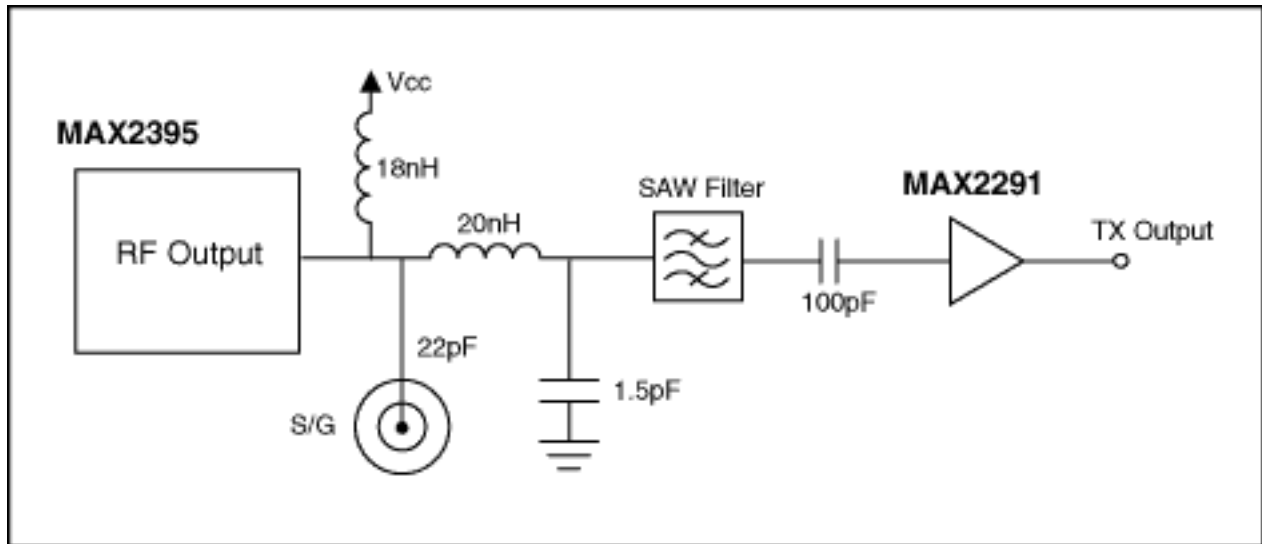

Figure 4. MAX2395 Output to SAW Filter Input Match.

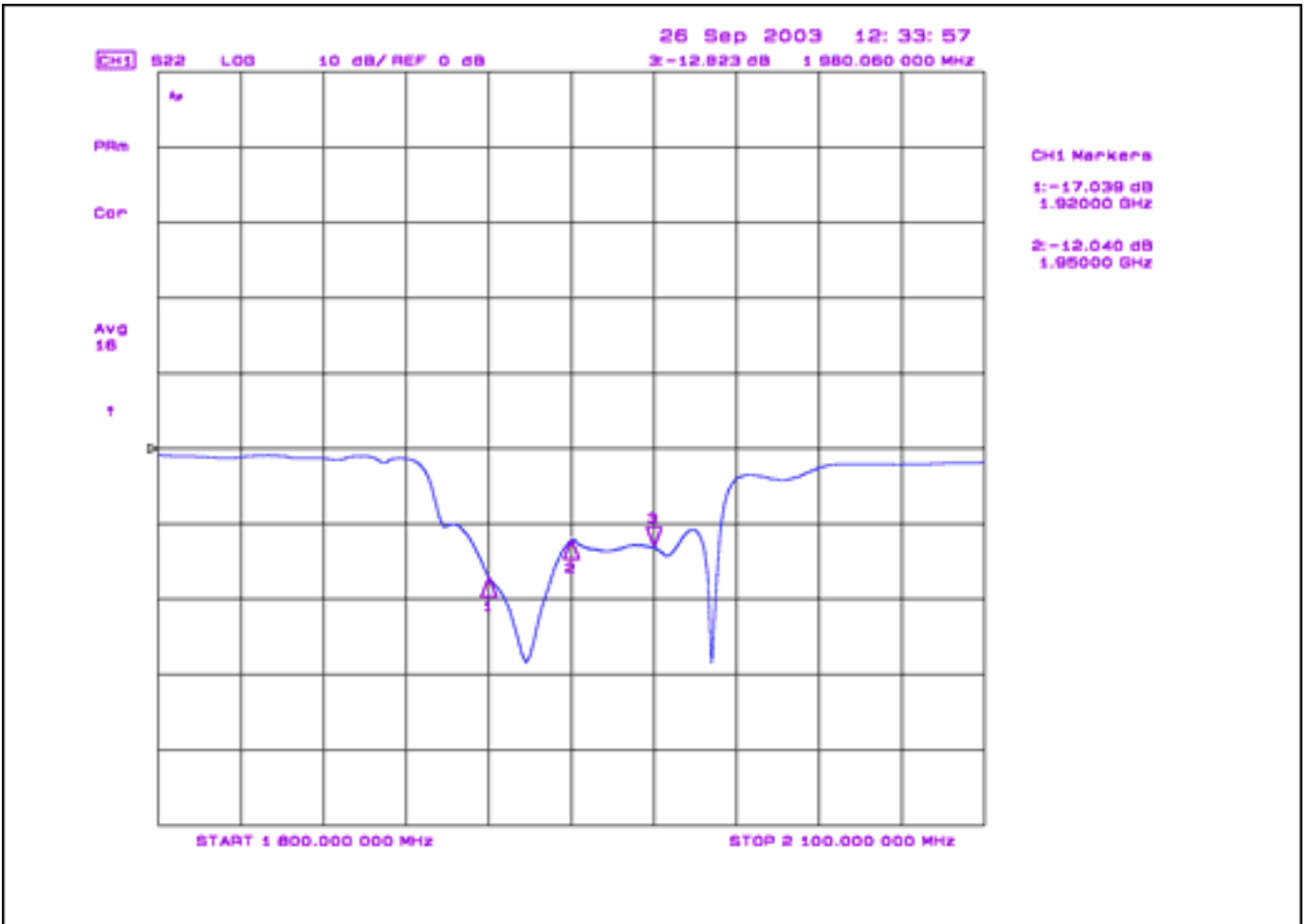

Figure 5. SAW filter output return loss, with revised matching circuit.